

P-CHANNEL ENHANCEMENT MODE POWER MOSFET

DESCRIPTION

The UTC **UT30P04** is a P-channel enhancement mode Power MOSFET, providing customers fast switching, ruggedized device design, low on-resistance and cost-effectiveness with UTC's advanced technology.

FEATURES

- * Low on-Resistance
- * Fast Switching Speed

SYMBOL

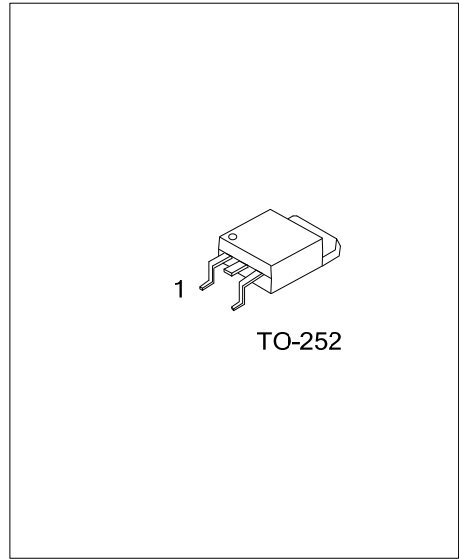
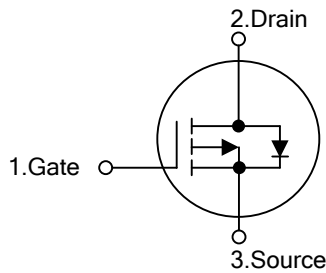

ORDERING INFORMATION

Ordering Number		Package	Pin Assignment			Packing
Lead Free	Halogen Free		1	2	3	
UT30P04L-TN3-R	UT30P04G-TN3-R	TO-252	G	D	S	Tape Reel

Note: Pin Assignment: G: Gate D: Drain S: Source

<p>UT30P04L-TN3-R</p> <ul style="list-style-type: none"> (1) Packing Type (2) Package Type (3) Green Package 	<ul style="list-style-type: none"> (1) R: Tape Reel (2) TN3: TO-252 (3) L: Lead Free, G: Halogen Free and Lead Free
---	--

MARKING

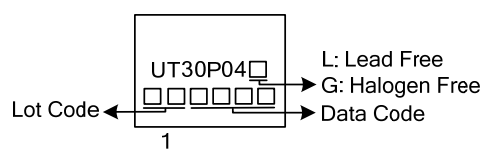

■ ABSOLUTE MAXIMUM RATINGS ($T_A=25^\circ\text{C}$ Unless Otherwise specified)

PARAMETER	SYMBOL	RATINGS	UNIT
Drain-Source Voltage	V_{DS}	-40	V
Gate-Source Voltage	V_{GS}	± 20	V
Continuous Drain Current	I_D	$T_C=25^\circ\text{C}$	-21
		$T_C=70^\circ\text{C}$	-17
Pulsed Drain Current (Note 2)	I_{DM}	-70	A
Avalanche Current	I_{AS}	-27	A
Avalanche Energy (Note 3)	E_{AS}	36	mJ
Power Dissipation	P_D	$T_C=25^\circ\text{C}$	30
		$T_C=70^\circ\text{C}$	20
Operating Junction Temperature	T_J	-55~150	$^\circ\text{C}$
Storage Temperature	T_{STG}	-55~150	$^\circ\text{C}$

- Notes: 1. Absolute maximum ratings are those values beyond which the device could be permanently damaged. Absolute maximum ratings are stress ratings only and functional device operation is not implied.
 2. Pulse width limited by maximum junction temperature.
 3. $V_{DD}=-20\text{V}$. Starting $T_J=25^\circ\text{C}$.

■ THERMAL DATA

PARAMETER	SYMBOL	RATINGS	UNIT
Junction to Ambient	θ_{JA}	40	$^\circ\text{C/W}$
Junction to Case	θ_{JC}	4.1	$^\circ\text{C/W}$

■ ELECTRICAL CHARACTERISTICS ($T_J = 25^\circ\text{C}$, unless otherwise specified)

PARAMETER	SYMBOL	TEST CONDITIONS	MIN	TYP	MAX	UNIT
OFF CHARACTERISTICS						
Drain-Source Breakdown Voltage	BV_{DSS}	$I_D = -250\mu\text{A}$, $V_{GS} = 0\text{V}$	-40			V
Drain-Source Leakage Current	I_{DSS}	$V_{DS} = -32\text{V}$, $V_{GS} = 0\text{V}$			1	μA
		$V_{DS} = -30\text{V}$, $V_{GS} = 0\text{V}$, $T_J = 125^\circ\text{C}$			10	
Gate- Source Leakage Current	I_{GSS}	$V_{DS} = 0\text{V}$, $V_{GS} = \pm 20\text{V}$			± 250	nA
On-State Drain Current (Note 1)	$I_{D(ON)}$	$V_{DS} = -5\text{V}$, $V_{GS} = -10\text{V}$	-70			A
ON CHARACTERISTICS						
Gate Threshold Voltage	$V_{GS(TH)}$	$V_{DS} = V_{GS}$, $I_D = -250\mu\text{A}$	-1	-2.5	-3	V
Static Drain-Source On-State Resistance (Note 1)	$R_{DS(ON)}$	$V_{GS} = -5\text{V}$, $I_D = -8\text{A}$		65	73	m Ω
		$V_{GS} = -7\text{V}$, $I_D = -8\text{A}$		35	50	
		$V_{GS} = -10\text{V}$, $I_D = -10\text{A}$		30	40	
Forward Transconductance (Note 1)	g_{FS}	$V_{DS} = -10\text{V}$, $I_D = -10\text{A}$		20		S
Gate Resistance	R_g	$V_{GS} = 0\text{V}$, $V_{DS} = 0\text{V}$, $f = 1.0\text{MHz}$		4.95		Ω
DYNAMIC PARAMETERS						
Input Capacitance	C_{ISS}	$V_{GS} = 0\text{V}$, $V_{DS} = -20\text{V}$, $f = 1.0\text{MHz}$		1090		pF
Output Capacitance	C_{OSS}			175		
Reverse Transfer Capacitance	C_{RSS}			91		
GATE CHARGE (Note 2)						
Total Gate Charge	$Q_G (V_{GS} = -10\text{V})$	$V_{DS} = 0.5V_{(BR)DSS}$, $I_D = -18\text{A}$		17		nC
	$Q_G (V_{GS} = -4.5\text{V})$			8.5		
Gate to Source Charge	Q_{GS}			5.5		
Gate to Drain Charge	Q_{GD}			3		
SWITCHING PARAMETERS (Note 2)						
Turn-ON Delay Time	$t_{D(ON)}$	$V_{GS} = -10\text{V}$, $V_{DS} = -20\text{V}$, $I_D \approx -10\text{A}$, $R_{GS} = 6\Omega$, $R_L = 2\Omega$		6		ns
Rise Time	t_R			16		ns
Turn-OFF Delay Time	$t_{D(OFF)}$			26		ns
Fall-Time	t_F			10		ns
SOURCE- DRAIN DIODE RATINGS AND CHARACTERISTICS						
Continuous Current	I_S				-21	A
Drain-Source Diode Forward Voltage ¹	V_{SD}	$I_F = -10\text{A}$, $V_{GS} = 0\text{V}$			-1.2	V
Reverse Recovery Time	t_{RR}	$I_F = -10\text{A}$, $dI_F/dt = 100\text{A}/\mu\text{s}$		15.5		ns
Reverse Recovery Charge	Q_{RR}			7.9		nC

Notes: 1. Pulsed test: Pulse width $\leq 300\mu\text{sec}$, duty cycle $\leq 2\%$.

2. Independent of operating temperature.

■ TYPICAL CHARACTERISTICS

