

# 150N03

## 150 Amps,30 Volts N-CHANNEL MOSFET

### Features

- 150A,30V, $R_{DS(ON)MAX}=2.5m\Omega @V_{GS}=10V/20A$   
 $R_{DS(ON)MAX}=2.8m\Omega @V_{GS}=4.5V/20A$
- Low gate charge
- Low  $C_{iss}$
- Fast switching
- 100% avalanche tested
- Improved dv/dt capability

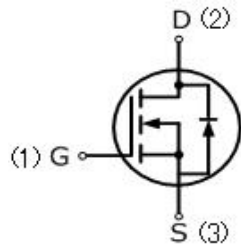

TO-252  
150N03GSL

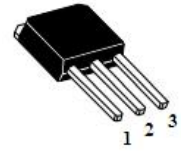

TO-251  
150N03DSL

### Absolute Maximum Ratings ( $T_C=25^\circ C$ , unless otherwise noted)

Parameter	Symbol	150N03	UNIT
Drain-Source Voltage	$V_{DSS}$	30	V
Gate-Source Voltage	$V_{GSS}$	$\pm 20$	
Continuous Drain Current	$I_D$	150	A
Pulsed Drain Current(Note1)	$I_{DM}$	440	
Single Pulse Avalanche Energy (Note 2)	$E_{AS}$	500	mJ
Operating Junction and Storage Temperature Range	$T_J, T_{STG}$	-55 to +150	$^\circ C$
Maximum lead temperature for soldering purposes, 1/8" from case for 5 seconds	$T_L$	260	$^\circ C$

### Thermal Characteristics

Parameter	Symbol	150N03	Units
Thermal resistance , Junction to Case	$R_{th(J-c)}$	1.3	$^\circ C/W$
Maximum Power Dissipation	$P_D$	96	W

Electrical Characteristics (T <sub>c</sub> =25°C,unless otherwise noted)						
Parameter	Symbol	Test Conditions	Min	Typ	Max	Units
<b>Off Characteristics</b>						
Drain-Source Breakdown Voltage	BV <sub>DSS</sub>	V <sub>GS</sub> =0V,I <sub>D</sub> =250uA	30	—	—	V
Zero Gate Voltage Drain Current	I <sub>DSS</sub>	V <sub>DS</sub> =30V,V <sub>GS</sub> =0V	—	—	1	uA
Gate-Body Leakage Current,Forward	I <sub>GSSF</sub>	V <sub>GS</sub> =20V,V <sub>DS</sub> =0V	—	—	100	nA
Gate-Body Leakage Current,Reverse	I <sub>GSSR</sub>	V <sub>GS</sub> =-20V,V <sub>DS</sub> =0V	—	—	-100	nA
<b>On Characteristics</b>						
Gate-Source Threshold Voltage	V <sub>GS(th)</sub>	V <sub>DS</sub> =V <sub>GS</sub> ,I <sub>D</sub> =250uA	1.0	—	3.0	V
Drain-Source On-State Resistance	R <sub>DS(on)</sub>	V <sub>GS</sub> =10V,I <sub>D</sub> =20A	—	2.0	2.5	m Ω
		V <sub>GS</sub> =4.5V,I <sub>D</sub> =20A	—	2.3	2.8	m Ω
<b>Dynamic Characteristics</b>						
Input Capacitance	C <sub>iss</sub>	V <sub>DS</sub> =25V,V <sub>GS</sub> =0V, f=1.0MHZ	—	7800	—	pF
Output Capacitance	C <sub>oss</sub>		—	948	—	pF
Reverse Transfer Capacitance	C <sub>rss</sub>		—	432	—	pF
<b>Switching Characteristics</b>						
Turn-On Delay Time	t <sub>d(on)</sub>	V <sub>DD</sub> =20V,I <sub>D</sub> =70A, R <sub>G</sub> =3.7Ω V <sub>GS</sub> =10V (Note3,4)	—	25	—	ns
Turn-On Rise Time	t <sub>r</sub>		—	42	—	ns
Turn-Off Delay Time	t <sub>d(off)</sub>		—	96	—	ns
Turn-Off Fall Time	t <sub>f</sub>		—	42	—	ns
Total Gate Charge	Q <sub>g</sub>	V <sub>DS</sub> =20V,I <sub>D</sub> =70A, V <sub>GS</sub> =4.5V (Note3,4)	—	70	—	nC
Gate-Source Charge	Q <sub>gs</sub>		—	15	—	nC
Gate-Drain Charge	Q <sub>gd</sub>		—	20	—	nC
<b>Drain-Source Body Diode Characteristics and Maximum Ratings</b>						
Diode Forward Voltage	V <sub>SD</sub>	I <sub>S</sub> =20A,V <sub>GS</sub> =0V	—	—	1.1	V
Reverse Recovery Time	t <sub>rr</sub>	V <sub>GS</sub> =0V,I <sub>S</sub> =40A, dI <sub>F</sub> /dt=100A/us,(Note3)	—	23.5	—	ns
Reverse Recovery Charge	Q <sub>rr</sub>		—	22	—	nC

**Notes**

1. Repetitive Rating:pulse width limited by maximum junction temperature.
2. V<sub>DD</sub>=10V,L=0.5mH,R<sub>g</sub>=25 Ω , T<sub>J</sub>=25°C .
3. dI/dt=200A/us,starting T<sub>J</sub>=25°C.Pulse width≤300us;duty cycle≤2%.
4. Repetitive rating; pulse width limited by maximum junction temperature.

TEST CIRCUIT AND WAVEFORM

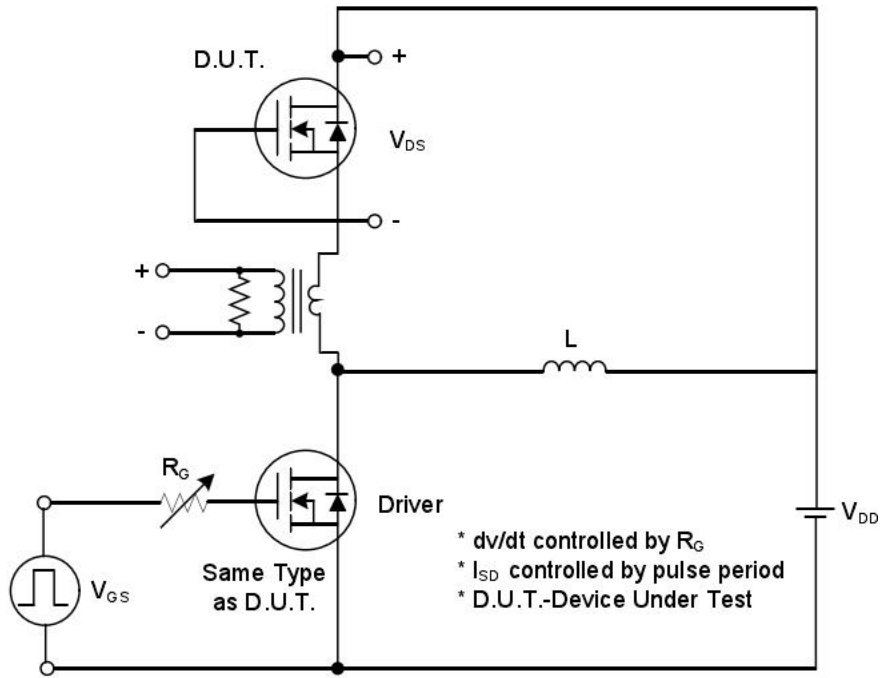

Peak Diode Recovery dv/dt Test Circuit

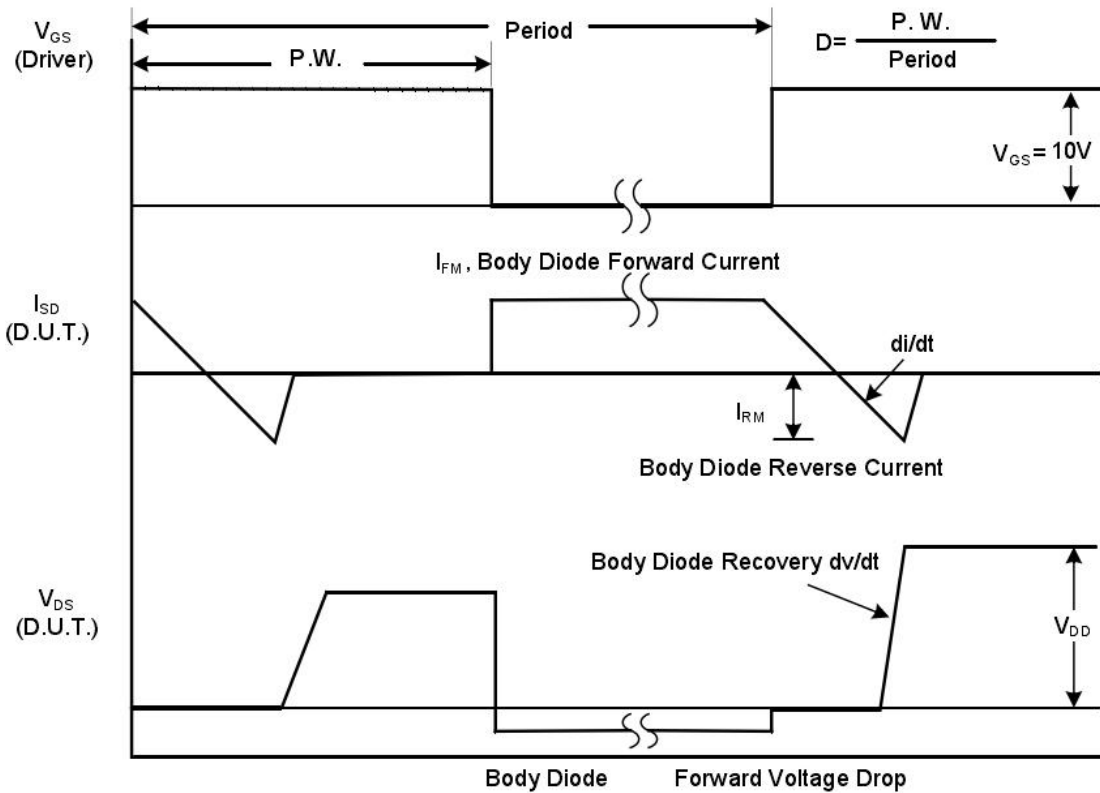

Peak Diode Recovery dv/dt Waveforms

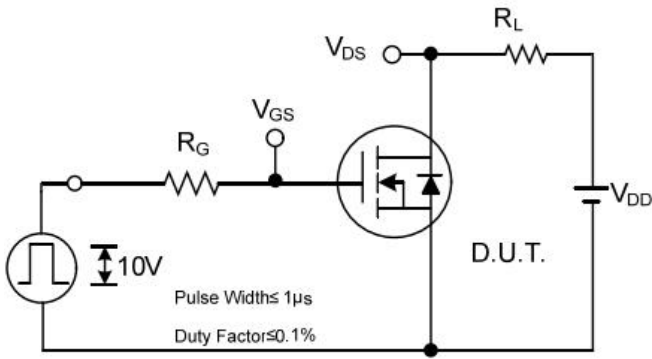

**Switching Test Circuit**

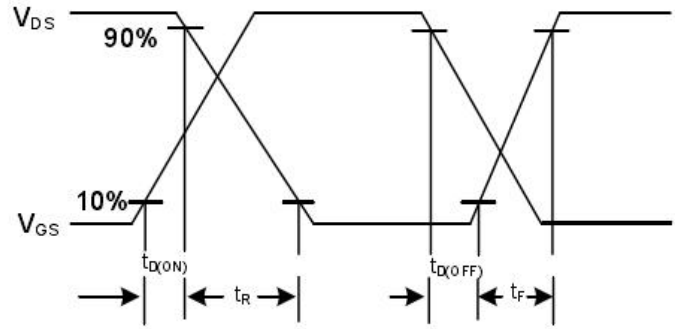

**Switching Waveforms**

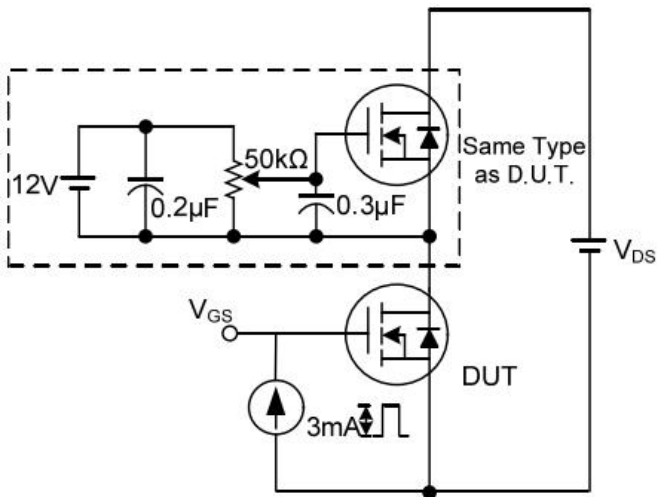

**Gate Charge Test Circuit**

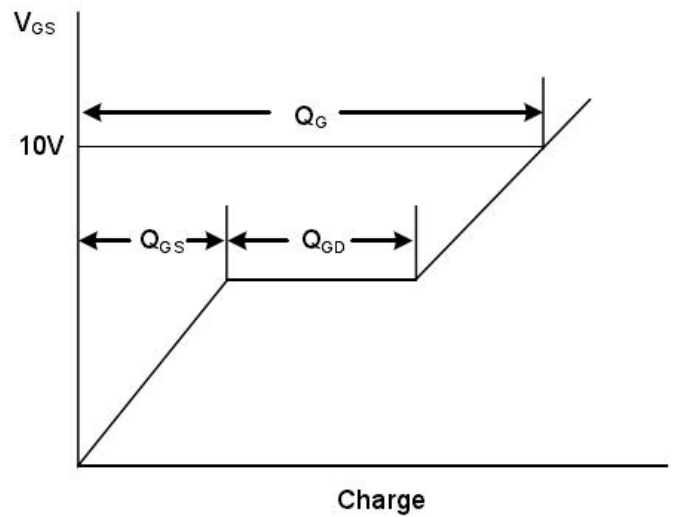

**Gate Charge Waveform**

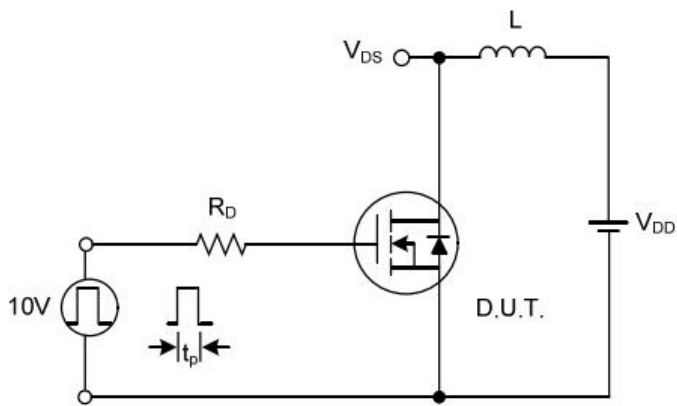

**Unclamped Inductive Switching Test Circuit**

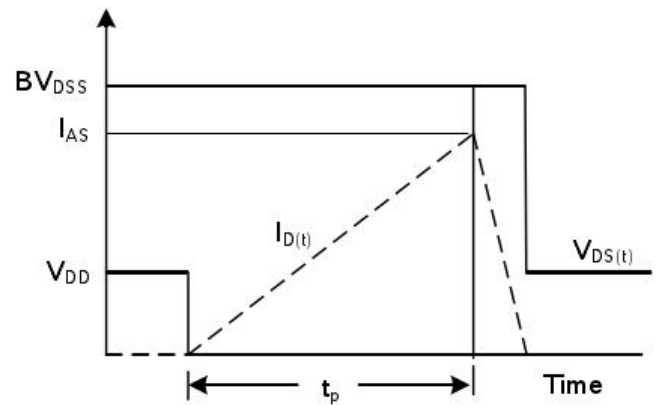

**Unclamped Inductive Switching Waveforms**

RATING AND CHARACTERISTIC CURVES

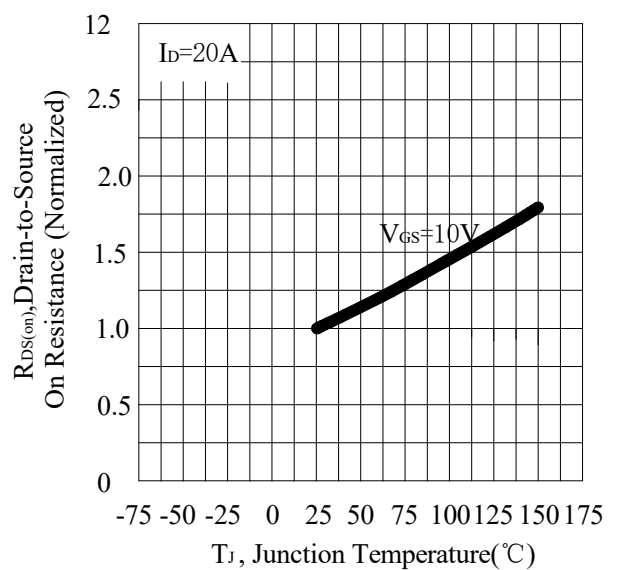
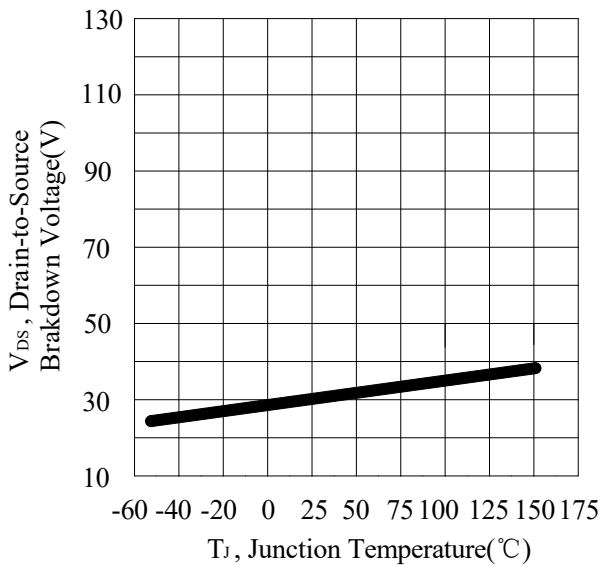
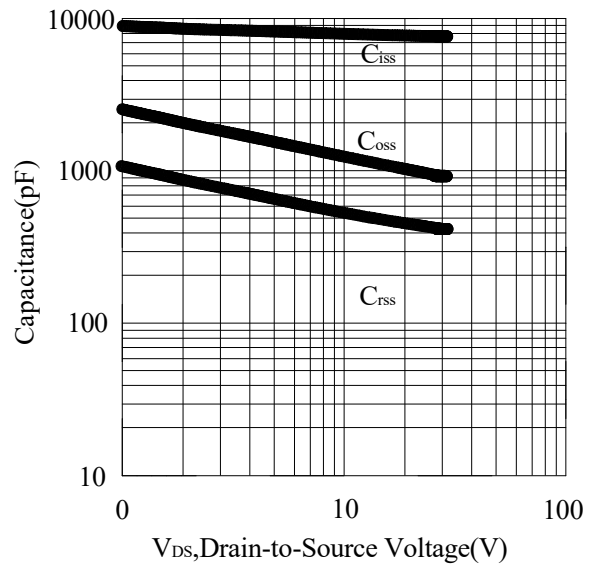
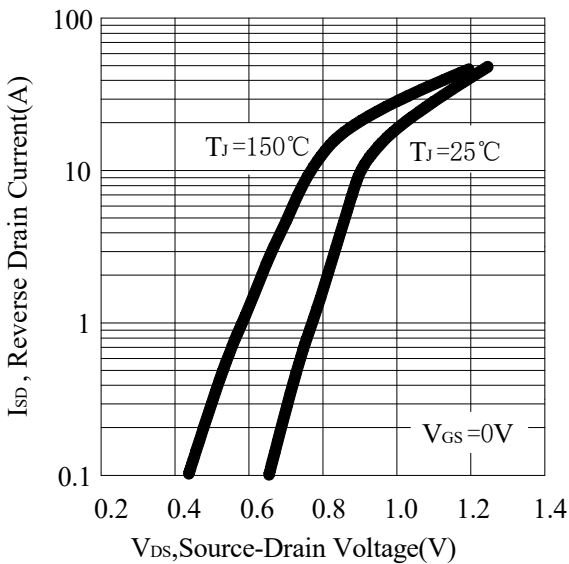
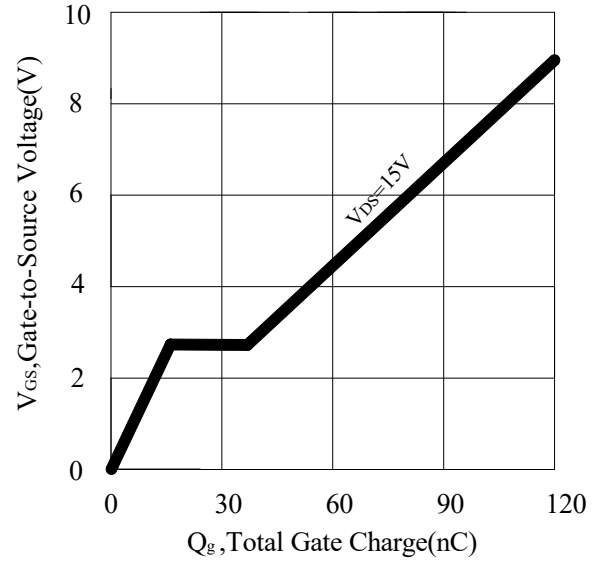
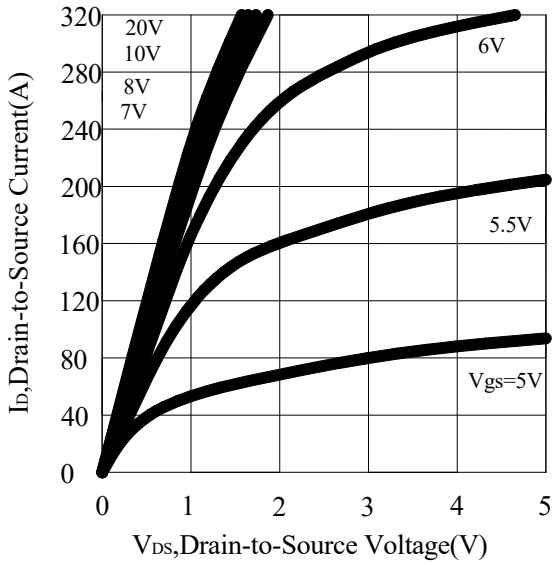

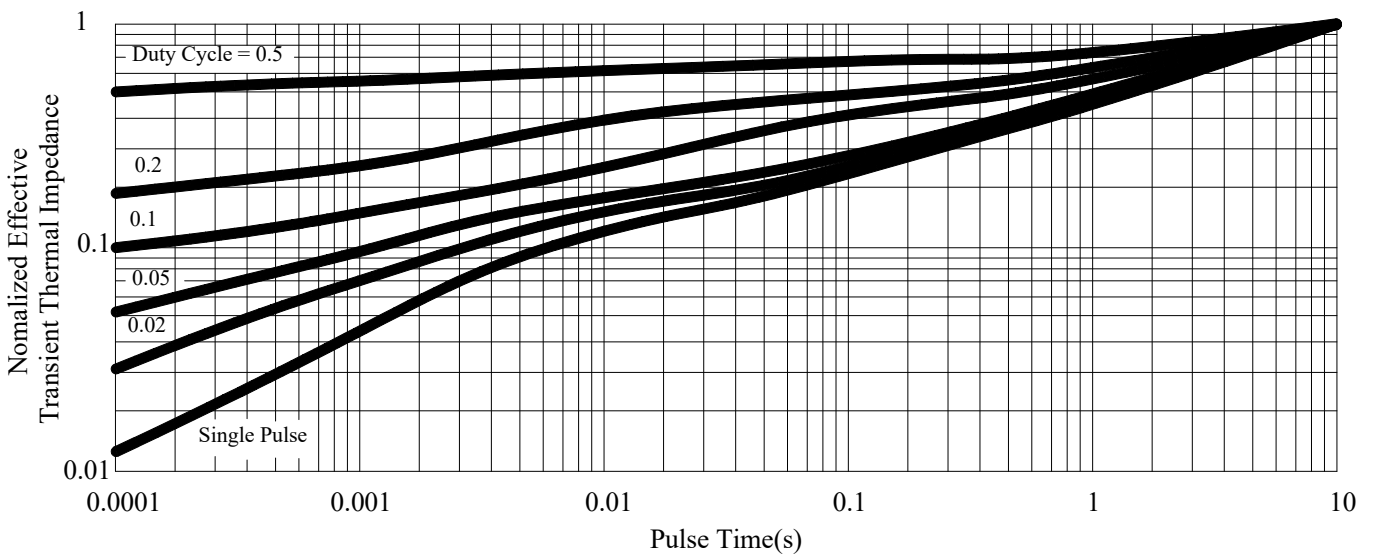
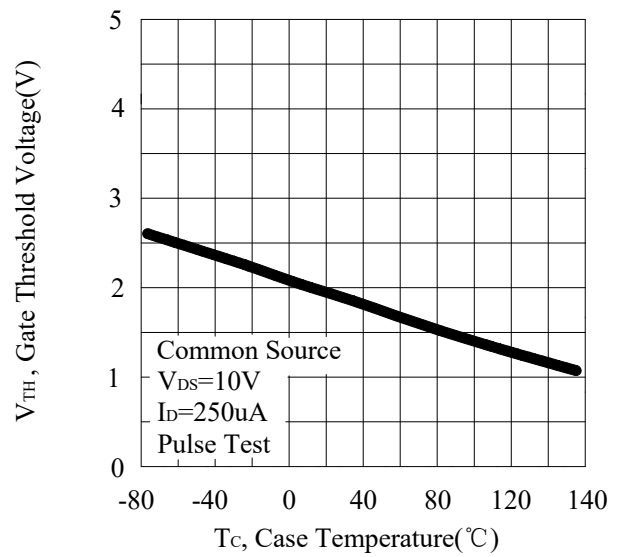
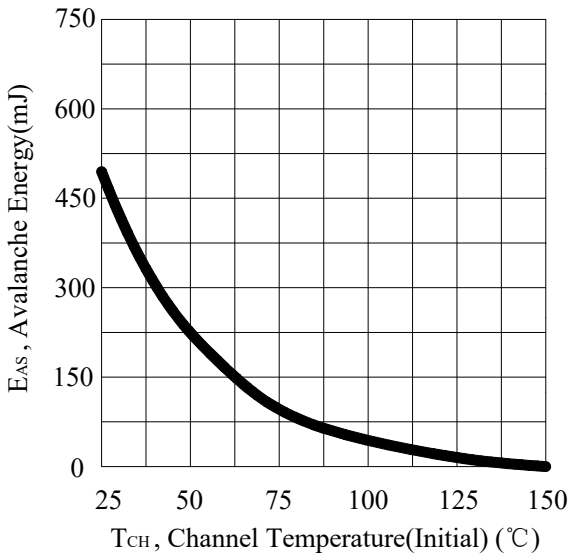
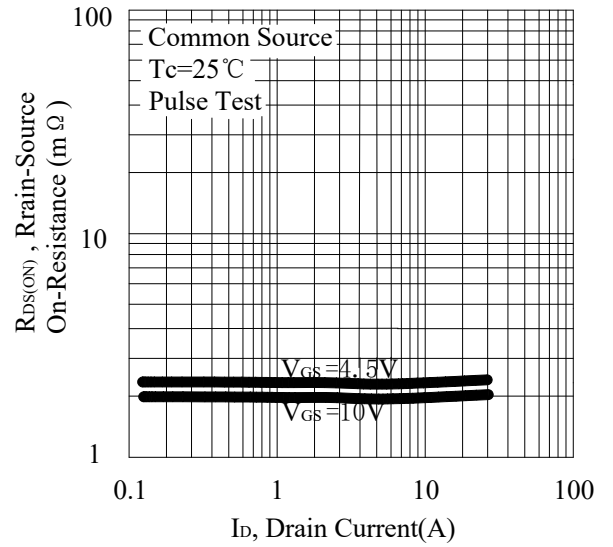
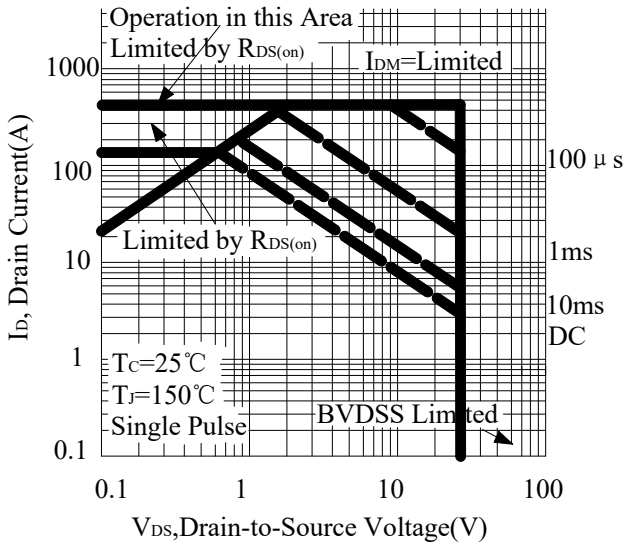

PACKAGE OUTLINE DIMENSIONS

**TO-252**

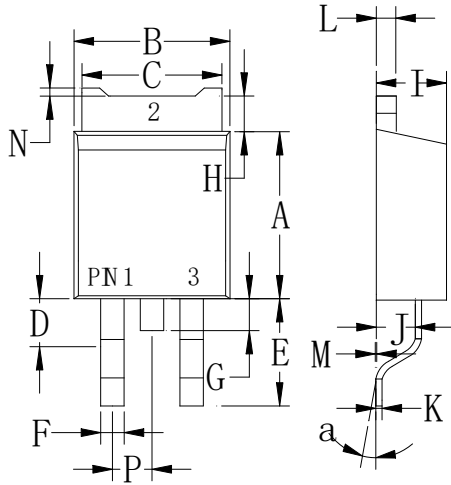

TO-252		
Dim	Min	Max
A	.230 (5.85)	.246 (6.25)
B	.250 (6.35)	.264 (6.75)
C	.207 (5.27)	.218 (5.54)
D	.037 (0.93)	.045 (1.14)
E	.106 (2.70)	.138 (3.50)
F	.028 (0.72)	.033 (0.84)
G	.024 (0.60)	.041 (1.05)
H	.028 (0.72)	.043 (1.10)
I	.085 (2.15)	.096 (2.45)
J	.037 (0.95)	.047 (1.20)
K	.018 (0.45)	.026 (0.65)
L	.018 (0.45)	.024 (0.60)
P	.081 (2.05)	.094 (2.40)
M	.000 (0.00)	.006 (0.15)
N	--	.008 (0.20)
a	0°	10°

Dimensions in inches and (millimeters)

**TO-251**

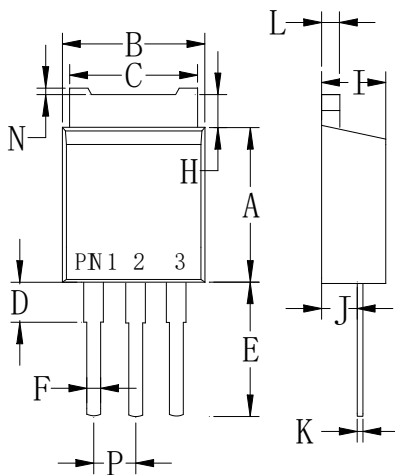

TO-251		
Dim	Min	Max
A	.230 (5.85)	.246 (6.25)
B	.250 (6.35)	.266 (6.75)
C	.207 (5.27)	.218 (5.54)
D	.037 (0.93)	.045 (1.14)
E	.173 (4.40)	.205 (5.20)
F	.028 (0.72)	.033 (0.84)
H	.028 (0.70)	.043 (1.10)
I	.085 (2.15)	.096 (2.45)
J	.037 (0.95)	.047 (1.20)
K	.018 (0.45)	.026 (0.65)
L	.018 (0.45)	.024 (0.60)
N	--	.008 (0.20)
P	.081 (2.05)	.094 (2.40)

Dimensions in inches and (millimeters)