

TO-251-3L Plastic-Encapsulate MOSFETS

CJD01N80 N-Channel Power MOSFET

GENERAL DESCRIPTION

The CJD01N80 is an N-channel mode power MOSFET using advanced technology to provide customers with planar stripe. This technology specializes in allowing a minimum on-state resistance and superior switching performance. It also can withstand high energy pulse in the avalanche and commutation mode. The CJD01N80 is universally applied in high efficiency switch mode power supply.

FEATURE

- Excellent package for good heat dissipation
- High switching speed
- 100% avalanche tested

APPLICATION

- Power switching application
- DC/DC converters

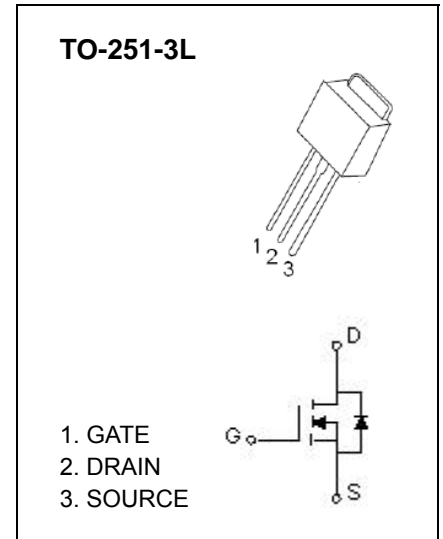

Maximum ratings ($T_a=25^{\circ}\text{C}$ unless otherwise noted)

| Parameter | Symbol | Value | Unit |
|--|-----------------|------------|-----------------------------|
| Drain-Source Voltage | V_{DS} | 800 | V |
| Gate-Source Voltage | V_{GS} | ± 30 | |
| Continuous Drain Current | I_D | 1 | A |
| Pulsed Drain Current | I_{DM} | 4 | |
| Single Pulsed Avalanche Energy (note1) | E_{AS} | 90 | mJ |
| Thermal Resistance from Junction to Ambient | $R_{\theta JA}$ | 100 | $^{\circ}\text{C}/\text{W}$ |
| Junction Temperature | T_J | 150 | $^{\circ}\text{C}$ |
| Storage Temperature Range | T_{STG} | -55 ~ +150 | |
| Maximum Lead Temperature for Soldering Purposes , 1/8"from Case for 5 Seconds | T_L | 260 | |

Electrical characteristics (T_a=25°C unless otherwise noted)

| Parameter | Symbol | Test Condition | Min | Typ | Max | Unit |
|---|----------------------|---|-----|------|------|------|
| Off characteristics | | | | | | |
| Drain-source breakdown voltage | V _{(BR)DSS} | V _{GS} = 0V, I _D =250μA | 800 | | | V |
| Zero gate voltage drain current | I _{DSS} | V _{DS} =800V, V _{GS} =0V | | | 10 | μA |
| Gate-body leakage current | I _{GSS} | V _{DS} =0V, V _{GS} =±30V | | | ±100 | nA |
| On characteristics | | | | | | |
| Gate-threshold voltage | V _{GS(th)} | V _{DS} =V _{GS} , I _D =250μA | 3 | | 5 | V |
| Static drain-source on-resistance | R _{DS(on)} | V _{GS} =10V, I _D =0.5A | | | 13.5 | Ω |
| Forward transconductance (note2) | g _{fs} | V _{DS} =50V, I _D =0.5A | | 0.75 | | S |
| Dynamic characteristics (note 3) | | | | | | |
| Input capacitance | C _{iss} | V _{DS} =25V, V _{GS} =0V, f =1MHz | | | 195 | pF |
| Output capacitance | C _{oss} | | | | 26 | |
| Reverse transfer capacitance | C _{rss} | | | | 3.5 | |
| Switching characteristics (note 2,3) | | | | | | |
| Turn-on delay time | t _{d(on)} | V _{DD} =400V, R _G =25Ω, I _D =1A | | | 30 | ns |
| Turn-on rise time | t _r | | | | 60 | |
| Turn-off delay time | t _{d(off)} | | | | 40 | |
| Turn-off fall time | t _f | | | | 60 | |
| Total Gate Charge | Q _g | V _{DS} =640V, V _{GS} =10V, I _D =1A | | | 7.2 | nC |
| Gate-Source Charge | Q _{gs} | | | 1.1 | | nC |
| Gate-Drain Charge | Q _{gd} | | | 3.3 | | nC |
| Drain-Source Diode Characteristics | | | | | | |
| Drain-source diode forward voltage | V _{SD} | V _{GS} = 0V, I _S =1A | | | 1.4 | V |
| Continuous drain-source diode forward current | I _S | | | | 1 | A |
| Pulsed drain-source diode forward current | I _{SM} | | | | 4 | A |

Notes :

1. I_L=1A, V_{DD}=50V, R_G=25Ω, Starting T_J=25°C
2. Pulse Test : Pulse width≤300μs, duty cycle ≤2%
3. Guaranteed by design, not subject to production

Typical Characteristics

CJD01N80

Output Characteristics

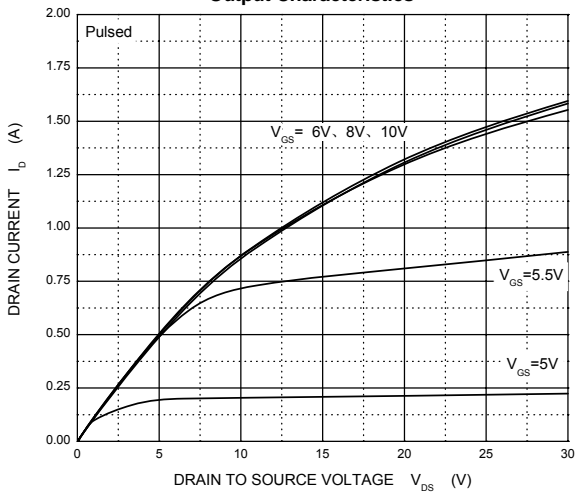

Transfer Characteristics

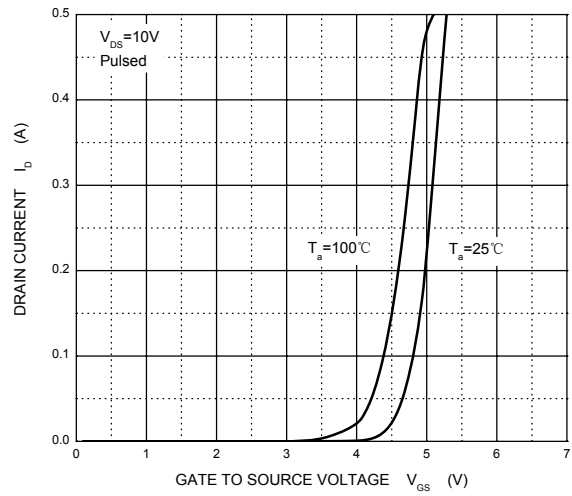

$R_{DS(ON)}$ — I_D

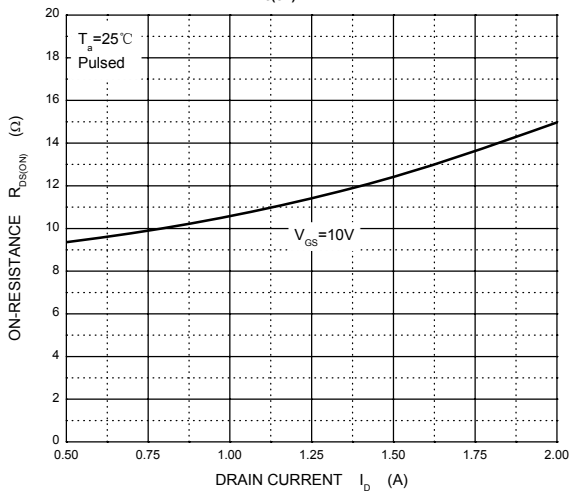

$R_{DS(ON)}$ — V_{GS}

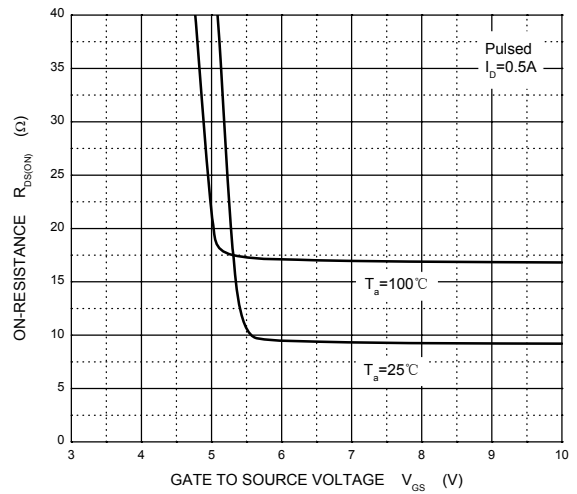

I_S — V_{SD}

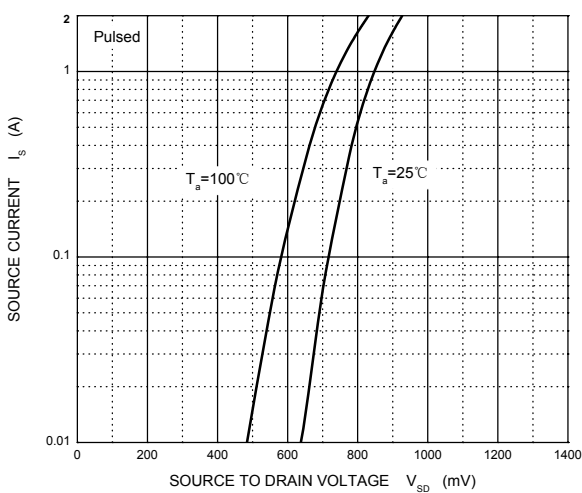

Threshold Voltage

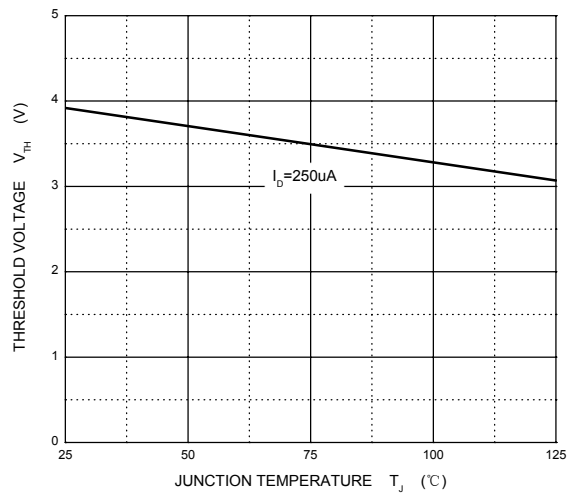

TO-251-3L Package Outline Dimensions

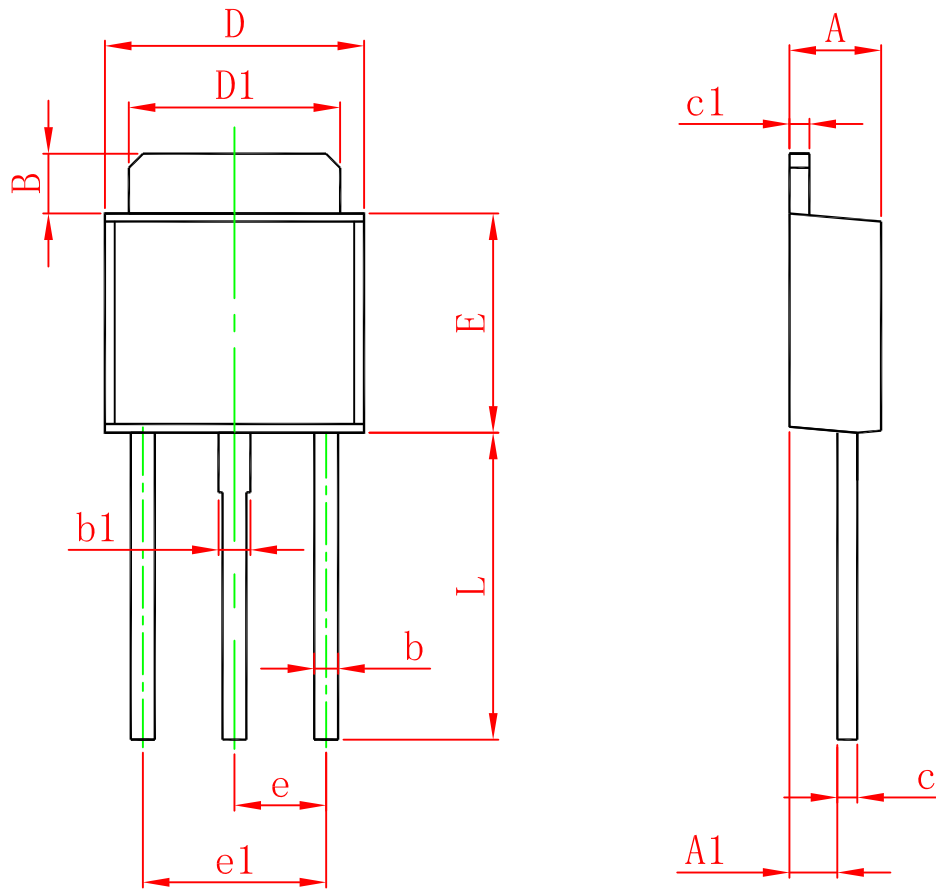

| Symbol | Dimensions In Millimeters | | Dimensions In Inches | |
|--------|---------------------------|-------|----------------------|-------|
| | Min. | Max. | Min. | Max. |
| A | 2.200 | 2.400 | 0.087 | 0.094 |
| A1 | 1.050 | 1.350 | 0.042 | 0.054 |
| B | 1.350 | 1.650 | 0.053 | 0.065 |
| b | 0.500 | 0.700 | 0.020 | 0.028 |
| b1 | 0.700 | 0.900 | 0.028 | 0.035 |
| c | 0.430 | 0.580 | 0.017 | 0.023 |
| c1 | 0.430 | 0.580 | 0.017 | 0.023 |
| D | 6.350 | 6.650 | 0.250 | 0.262 |
| D1 | 5.200 | 5.400 | 0.205 | 0.213 |
| E | 5.400 | 5.700 | 0.213 | 0.224 |
| e | 2.300 TYP. | | 0.091 TYP. | |
| e1 | 4.500 | 4.700 | 0.177 | 0.185 |
| L | 7.500 | 7.900 | 0.295 | 0.311 |