

7N60

Power MOSFET

7.4A, 600V N-CHANNEL POWER MOSFET

■ DESCRIPTION

The **7N60** is a high voltage power MOSFET and is designed to have better characteristics, such as fast switching time, low gate charge, low on-state resistance and have a high rugged avalanche characteristics. This power MOSFET is usually used at high speed switching applications in switching power supplies and adaptors.

■ FEATURES

- * $R_{DS(ON)} < 1.0\Omega$ @ $V_{GS} = 10V$
- * Fast Switching Capability
- * Avalanche Energy Tested
- * Improved dv/dt Capability, High Ruggedness

■ SYMBOL

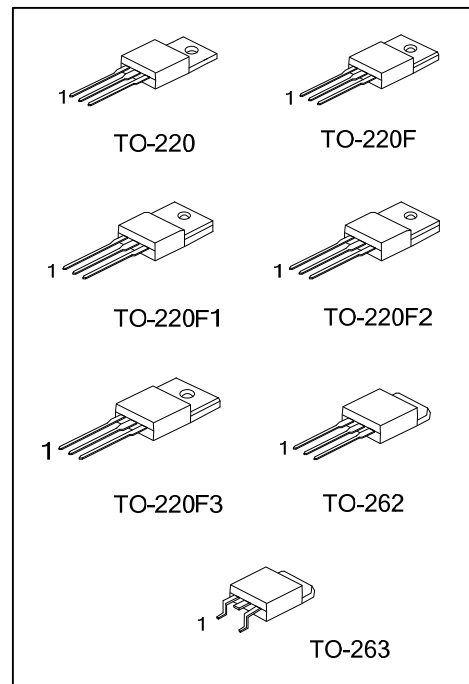
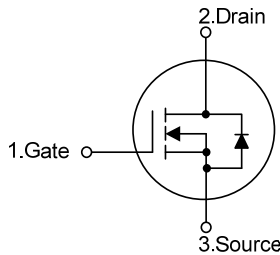

■ ORDERING INFORMATION

Ordering Number		Package	Pin Assignment			Packing
Lead Free	Halogen Free		1	2	3	
7N60L-TA3-T	7N60G-TA3-T	TO-220	G	D	S	Tube
7N60L-TF3-T	7N60G-TF3-T	TO-220F	G	D	S	Tube
7N60L-TF1-T	7N60G-TF1-T	TO-220F1	G	D	S	Tube
7N60L-TF2-T	7N60G-TF2-T	TO-220F2	G	D	S	Tube
7N60L-TF3T-T	7N60G-TF3T-T	TO-220F3	G	D	S	Tube
7N60L-T2Q-T	7N60G-T2Q-T	TO-262	G	D	S	Tube
7N60L-TQ2-T	7N60G-TQ2-T	TO-263	G	D	S	Tube
7N60L-TQ2-R	7N60G-TQ2-R	TO-263	G	D	S	Tape Reel

Note: Pin Assignment: G: Gate D: Drain S: Source

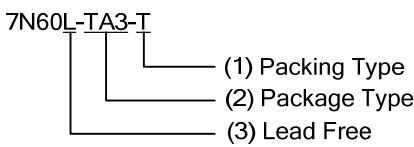
<p>7N60L-TA3-T</p>  <p>(1) Packing Type (2) Package Type (3) Lead Free</p>	<p>(1) T: Tube, R: Tape Reel (2) TA3: TO-220, TF1: TO-220F1, TF3: TO-220F TF2: TO-220F2, TF3T: TO-220F3, T2Q: TO-262 TQ2: TO-263 (3) L: Lead Free, G: Halogen Free</p>
---	--

■ MARKING INFORMATION

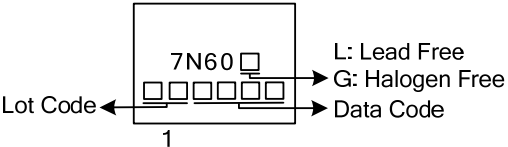
PACKAGE	MARKING
TO-220 TO-220F TO-220F1 TO-220F2 TO-220F3 TO-262 TO-263	 <p> L: Lead Free G: Halogen Free Data Code </p>

■ ABSOLUTE MAXIMUM RATINGS ($T_C = 25^\circ\text{C}$, unless otherwise specified)

PARAMETER		SYMBOL	RATINGS	UNIT
Drain-Source Voltage		V_{DSS}	600	V
Gate-Source Voltage		V_{GSS}	± 30	V
Avalanche Current (Note 2)		I_{AR}	7.4	A
Drain Current	Continuous	I_D	7.4	A
	Pulsed (Note 2)	I_{DM}	29.6	A
Avalanche Energy	Single Pulsed (Note 3)	E_{AS}	530	mJ
	Repetitive (Note 2)	E_{AR}	14.2	mJ
Peak Diode Recovery dv/dt (Note 4)		dv/dt	4.5	V/ns
Power Dissipation	TO-220/TO-262/TO-263	P_D	142	W
	TO-220F/TO-220F1		48	
	TO-220F3		50	
	TO-220F2			
Junction Temperature		T_J	+150	$^\circ\text{C}$
Storage Temperature		T_{STG}	-55 ~ +150	$^\circ\text{C}$

Notes: 1. Absolute maximum ratings are those values beyond which the device could be permanently damaged.

Absolute maximum ratings are stress ratings only and functional device operation is not implied.

2. Repetitive Rating : Pulse width limited by T_J .

3. $L=19.5\text{mH}$, $I_{AS}=7.4\text{A}$, $V_{DD}=50\text{V}$, $R_G=25\ \Omega$, Starting $T_J = 25^\circ\text{C}$

4. $I_{SD} \leq 7.4\text{A}$, $di/dt \leq 200\text{A}/\mu\text{s}$, $V_{DD} \leq BV_{DSS}$, Starting $T_J = 25^\circ\text{C}$

■ THERMAL DATA

PARAMETER		SYMBOL	RATINGS	UNIT
Junction to Ambient		θ_{JA}	62.5	$^\circ\text{C}/\text{W}$
Junction to Case	TO-220/TO-262/TO-263	θ_{JC}	0.88	$^\circ\text{C}/\text{W}$
	TO-220F/TO-220F1		2.6	
	TO-220F3			
	TO-220F2		2.5	

■ ELECTRICAL CHARACTERISTICS (T_C=25°C, unless otherwise specified)

PARAMETER	SYMBOL	TEST CONDITIONS	MIN	TYP	MAX	UNIT
OFF CHARACTERISTICS						
Drain-Source Breakdown Voltage	BV _{DSS}	V _{GS} = 0V, I _D = 250μA	600			V
Drain-Source Leakage Current	I _{DSS}	V _{DS} = 600V, V _{GS} = 0V			1	μA
Gate- Source Leakage Current	Forward	I _{GSS}			100	nA
	Reverse				-100	nA
Breakdown Voltage Temperature Coefficient	ΔBV _{DSS} /ΔT _J	I _D =250μA, Referenced to 25°C		0.67		V/°C
ON CHARACTERISTICS						
Gate Threshold Voltage	V _{GS(TH)}	V _{DS} = V _{GS} , I _D = 250μA	2.0		4.0	V
Static Drain-Source On-State Resistance	R _{DS(ON)}	V _{GS} = 10V, I _D = 3.7A		0.83	1.0	Ω
DYNAMIC CHARACTERISTICS						
Input Capacitance	C _{ISS}	V _{DS} =25V, V _{GS} =0V, f=1.0 MHz		1200	1400	pF
Output Capacitance	C _{OSS}			125	155	pF
Reverse Transfer Capacitance	C _{RSS}			40	50	pF
SWITCHING CHARACTERISTICS						
Turn-On Delay Time	t _{D(ON)}	V _{DD} =300V, I _D =7.4A, R _G =25Ω (Note 1, 2)		65	95	ns
Turn-On Rise Time	t _R			180	210	ns
Turn-Off Delay Time	t _{D(OFF)}			320	360	ns
Turn-Off Fall Time	t _F			220	260	ns
SWITCHING CHARACTERISTICS						
Total Gate Charge	Q _G	V _{DS} =480V, I _D =7.4A, V _{GS} =10V (Note 1, 2)		210	230	nC
Gate-Source Charge	Q _{GS}			11		nC
Gate-Drain Charge	Q _{GD}			38		nC
DRAIN-SOURCE DIODE CHARACTERISTICS AND MAXIMUM RATINGS						
Drain-Source Diode Forward Voltage	V _{SD}	V _{GS} = 0V, I _S = 7.4 A			1.4	V
Maximum Continuous Drain-Source Diode Forward Current	I _S				7.4	A
Maximum Pulsed Drain-Source Diode Forward Current	I _{SM}				29.6	A
Reverse Recovery Time	t _{rr}	V _{GS} = 0V, I _S = 7.4 A,		320		ns
Reverse Recovery Charge	Q _{RR}	dI _F / dt = 100A/μs (Note 1)		2.4		μC

Notes: 1. Pulse Test: Pulse width ≤ 300μs, Duty cycle ≤ 2%.

2. Essentially independent of operating temperature.

■ TEST CIRCUITS AND WAVEFORMS

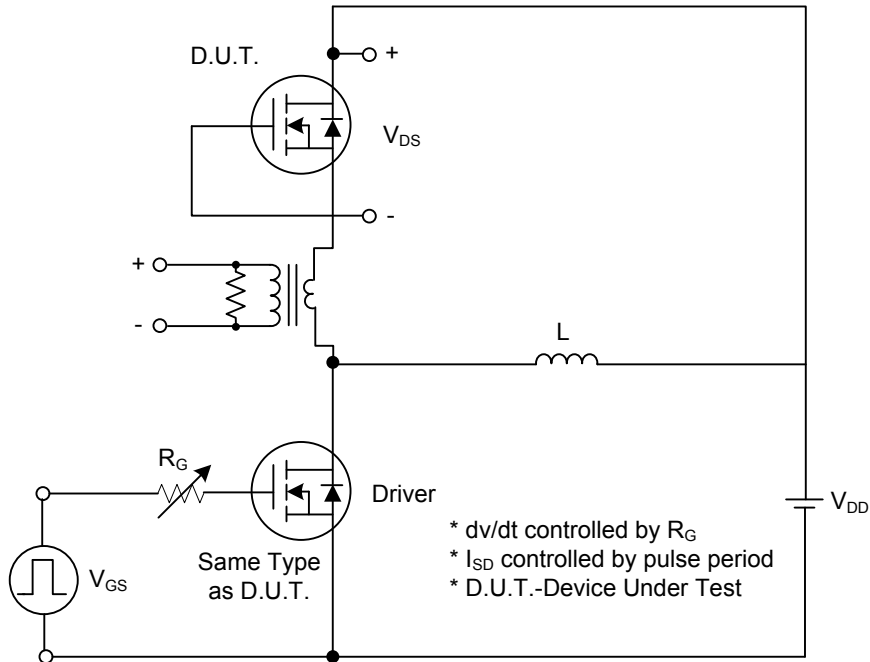

Peak Diode Recovery dv/dt Test Circuit

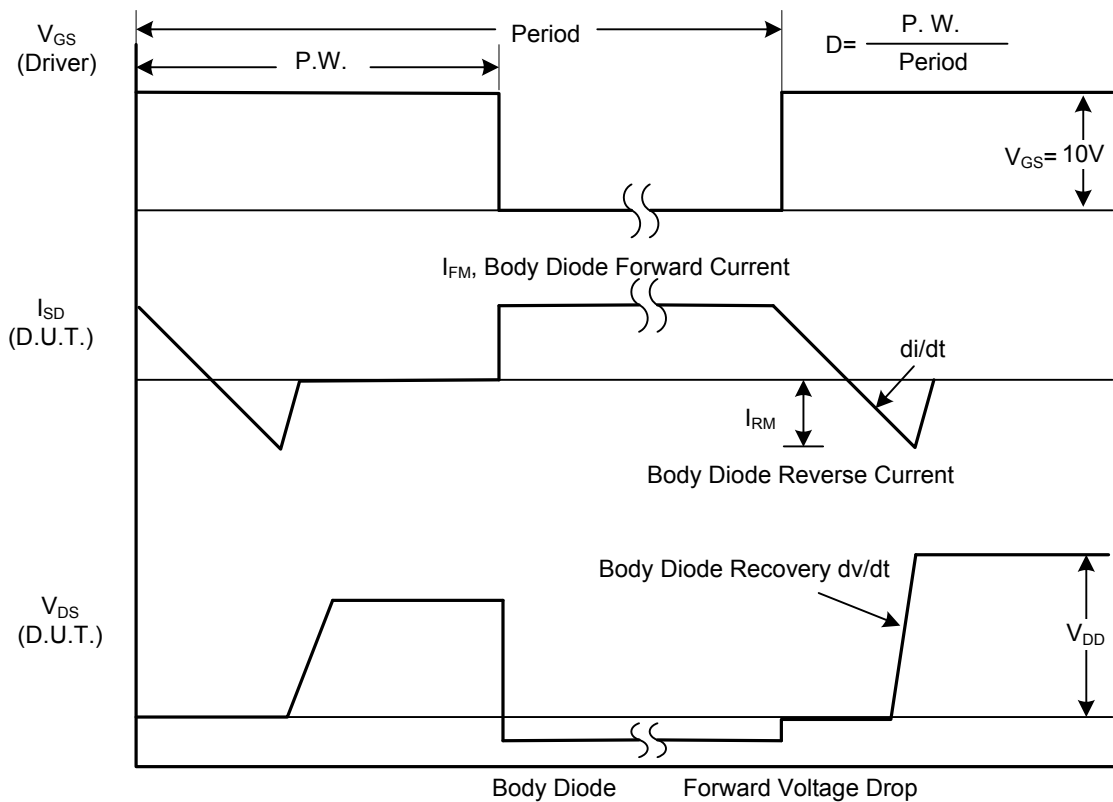

Peak Diode Recovery dv/dt Waveforms

■ TEST CIRCUITS AND WAVEFORMS (Cont.)

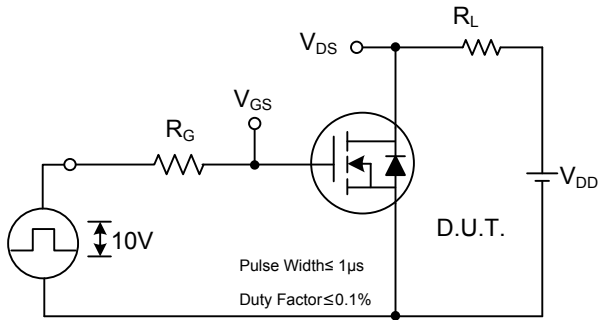

Switching Test Circuit

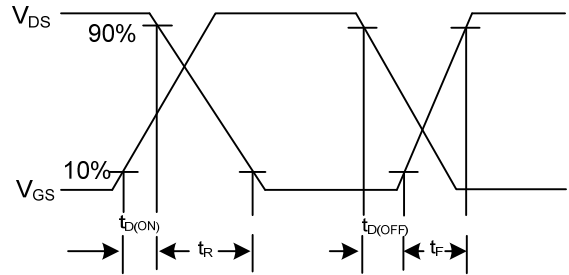

Switching Waveforms

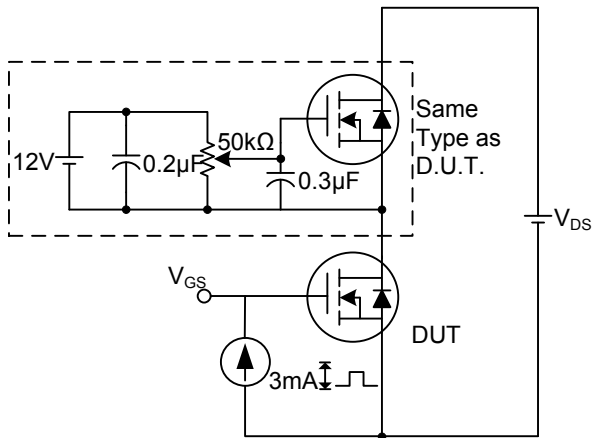

Gate Charge Test Circuit

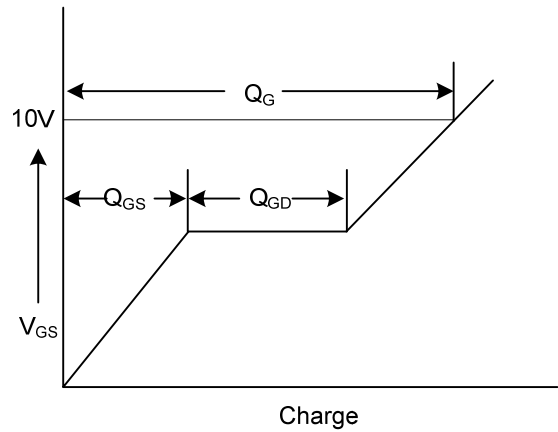

Gate Charge Waveform

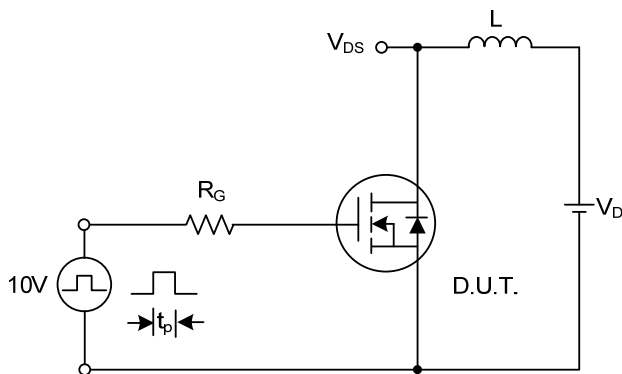

Unclamped Inductive Switching Test Circuit

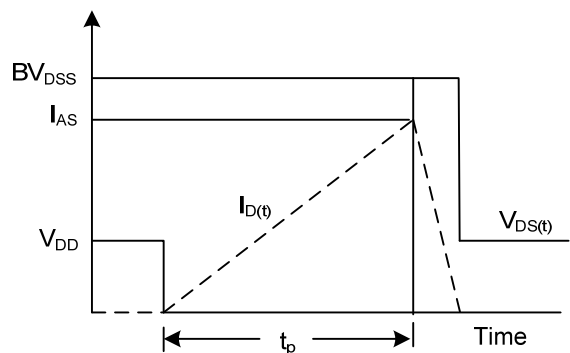

Unclamped Inductive Switching Waveforms

TYPICAL CHARACTERISTICS

On-State Characteristics

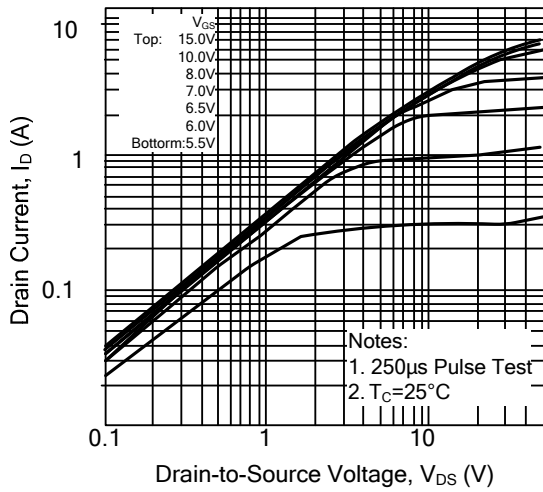

Transfer Characteristics

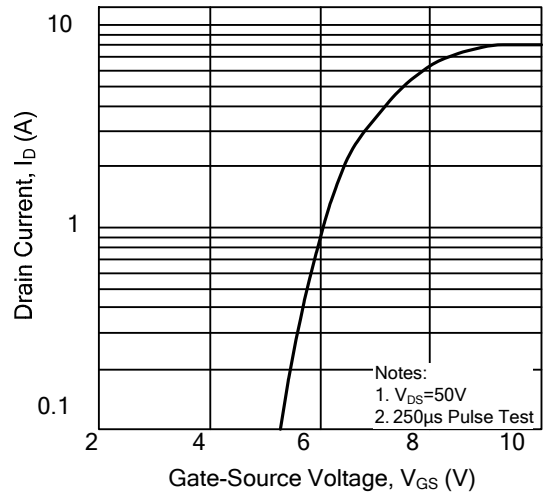

On-Resistance Variation vs. Drain Current and Gate Voltage

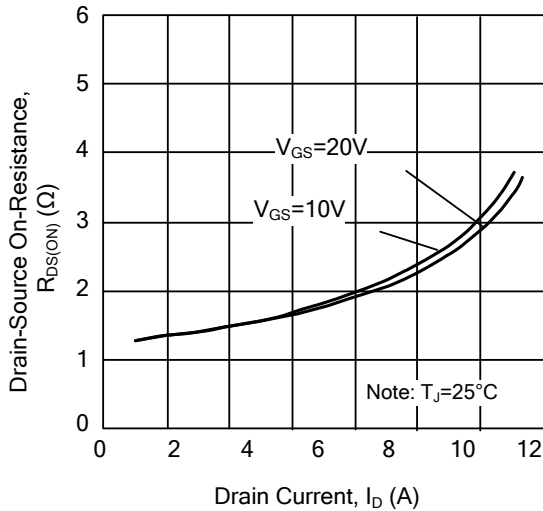

On State Current vs. Allowable Case Temperature

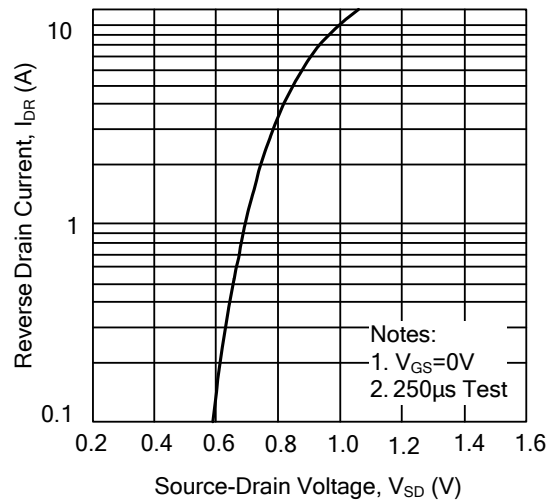

Capacitance Characteristics (Non-Repetitive)

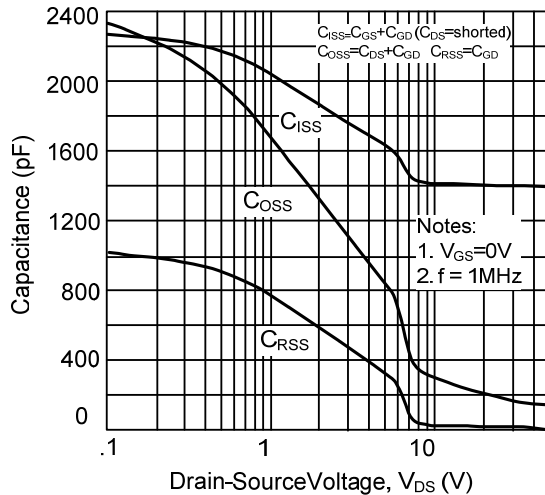

Gate Charge Characteristics

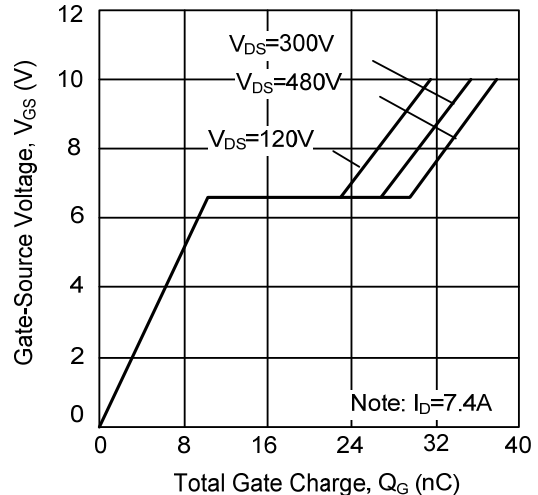

TYPICAL CHARACTERISTICS(Cont.)

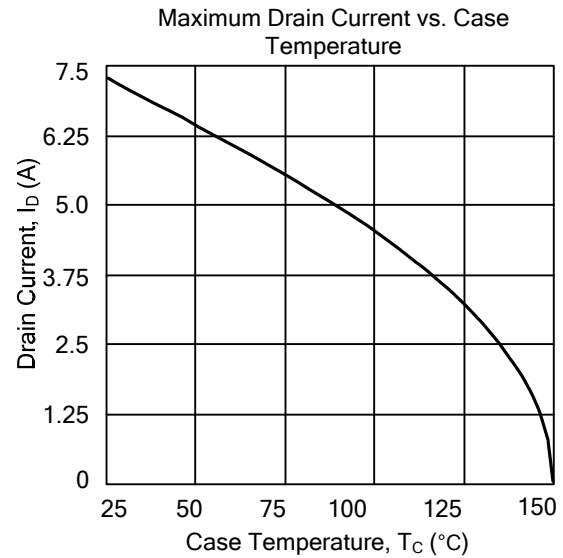
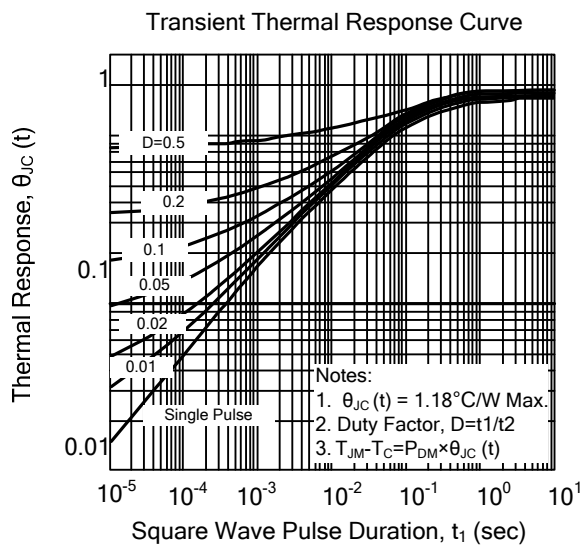
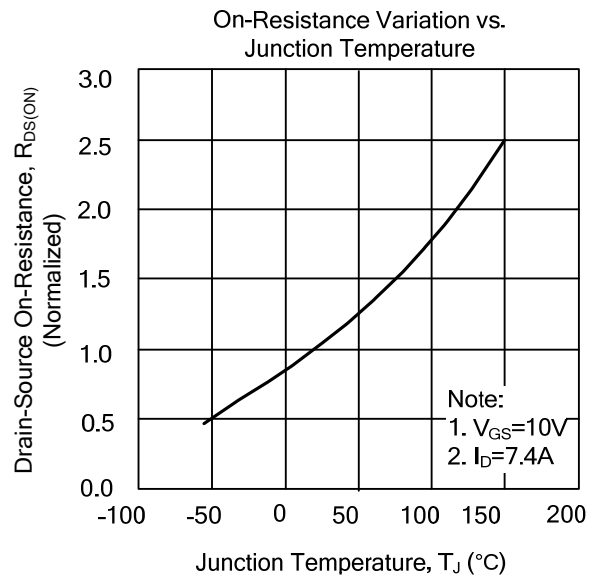
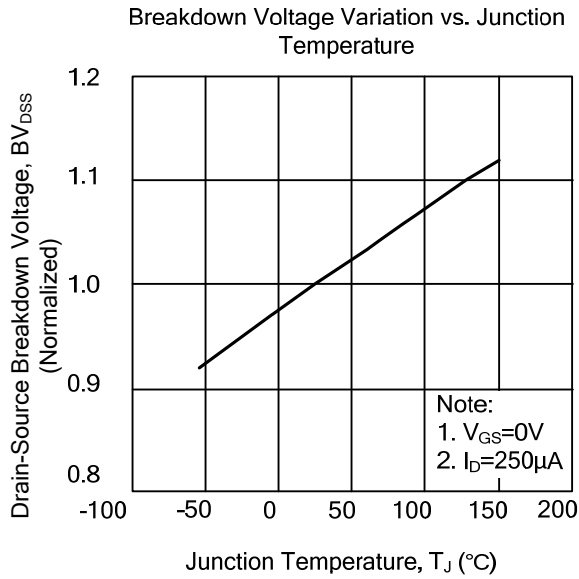

Safe Operating Area - 600V

